

# **JOHN BARSBY COMMUNITY SCHOOL**

***HOME OF THE BULLDOGS***

***Student/Parent Handbook 2019-2020***

**Ms. Jane Reynolds, Principal  
Ms. Theresa Kraeker, Vice-Principal  
Mr. Jeff Hasenauer, Vice-Principal**



**550 Seventh Street  
Nanaimo, BC V9R 3Z2  
Telephone (250) 753-8211  
Fax (250) 753-2430**

**TABLE OF CONTENTS**

<b>Welcome</b>	<b>Page 1</b>
<b>General Information</b>	<b>Pages 2 – 4</b>
<b>Code of Conduct</b>	<b>Pages 5 – 8</b>
<b>Student Support Services</b>	<b>Pages 9-11</b>
<b>Student Life</b>	<b>Pages 12 – 14</b>
<b>Evaluation/Reporting</b>	<b>Page 15</b>
<b>Safety</b>	<b>Pages 16-17</b>

**Dear Students and Parents,**

Welcome to John Barsby Community Secondary!

If you are new to our school and just beginning your high school experience, then you have five amazing years to look forward to. For returning parents and students, you already know why Barsby is a great place to learn. We are proud of our long tradition of excellence in academics, athletics and the fine arts, and we are excited to know that you will be a part of our journey this school year.

I believe in parental involvement and support, so please feel welcome at "our" school, anytime. We are committed to helping our students find their passion, and providing you opportunities to contribute to a home-school partnership in support of your child's success. We encourage your student to get involved in school activities, join multiple clubs, and athletic teams – there is something for everyone. This involvement in all aspects of Barsby should give them the necessary building blocks to be successful after graduation. At Barsby, the expectations for students and staff are clear and simple: "Do the right thing, Try your Best, and Get better each day".

This school year should be a positive experience for your student, and the staff at Barsby will do all they can to assist their learning experience, and help them achieve their desired goals. Please ensure that your student attends regularly, as that is the single largest predictor of student success and we have many supports available for all students. I want to encourage students to work hard this year and strive for success in all of their endeavors. Make Barsby your own and become part of the great Bulldawg tradition! Have a great year from all of us here at Barsby, we wish you the very best for the coming school year!

Ms. Jane Reynolds  
Principal

[Jane.Reynolds@sd68.bc.ca](mailto:Jane.Reynolds@sd68.bc.ca)

Mr. Jeff Hasenauer  
Vice Principal

[Jeff.Hasenauer@sd68.bc.ca](mailto:Jeff.Hasenauer@sd68.bc.ca)

Ms. Theresa Kraeker  
Vice Principal

[Theresa.Kraeker@sd68.bc.ca](mailto:Theresa.Kraeker@sd68.bc.ca)



## JOHN BARSBY COMMUNITY SCHOOL

### MISSION STATEMENT

At John Barsby we strive to prepare all students to become independent, productive and responsible citizens.

### VISION STATEMENT

At Barsby, we strive to connect with families and the community to create learning opportunities for students to become lifelong learners and productive members of society.

# SCHOOL MAP

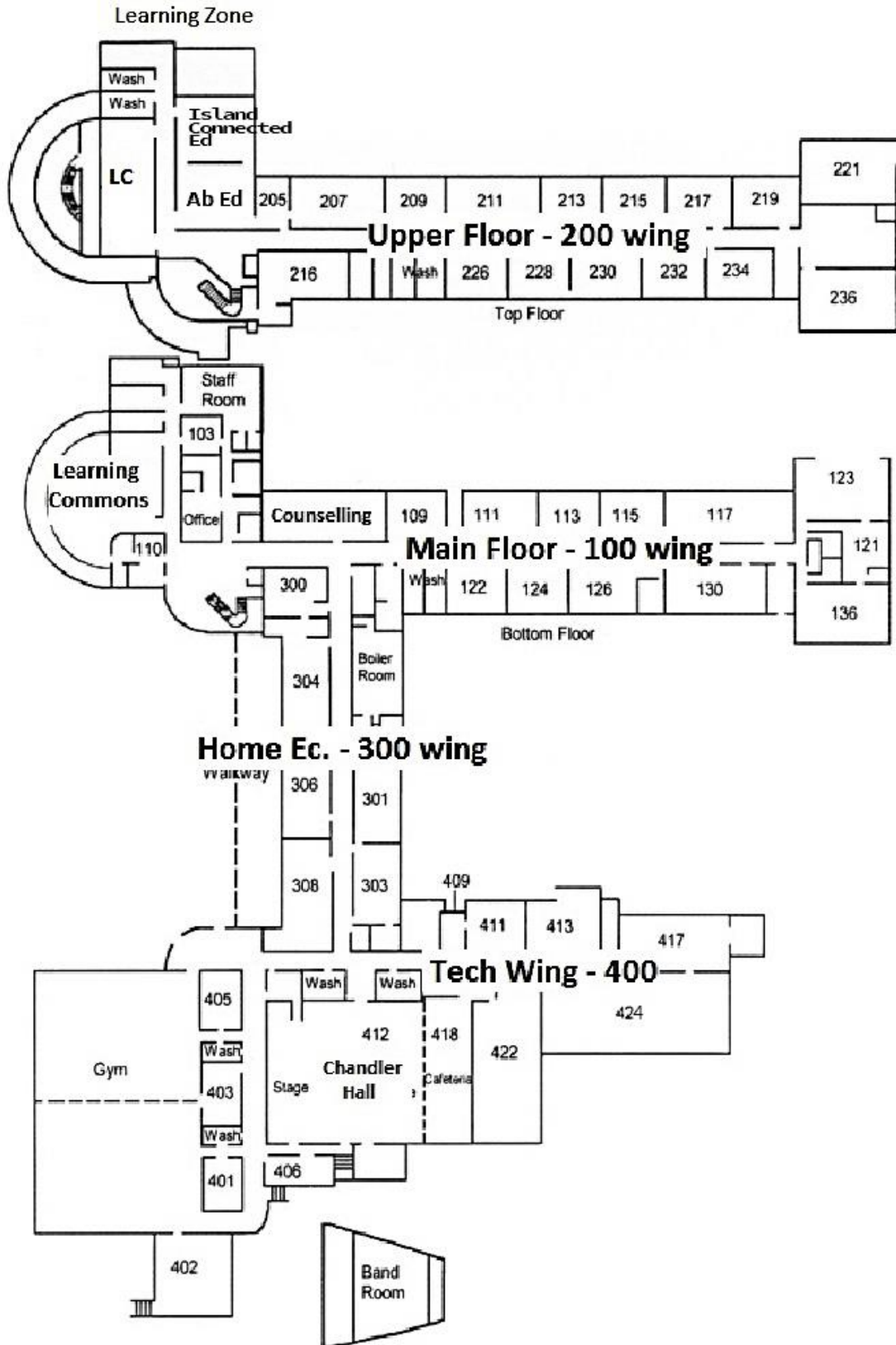

**JOHN BARSBY COMMUNITY SCHOOL BELL SCHEDULE 2019-2020**

	MONDAY	TUESDAY	WEDNESDAY	THURSDAY	FRIDAY
	Day 1	Day 2	Day 3	Day 4	Day 1,2,3 or 4
8:25	Warning Bell				
8:30	A.M. School Starts				
	69 min. A 8:30 – 9:39	84 min. C 8:30 – 9:54	84 min. B 8:30 – 9:54	84 min. D 8:30 – 9:54	69 min. 1st Block 8:30 – 9:39
	70 min. B 9:45 – 10:55	85 min. D 10:00 – 11:25	85 min. A 10:00 – 11:25	85 min. C 10:00 – 11:25	70 min. 2nd Block 9:45 – 10:55
LUNCH	10:55 – 11:35	11:25 – 12:05			10:55 – 11:35
Warning	11:30 Warning Bell	12:00 Warning Bell			11:30 Warning Bell
	PM School Starts 11:35	12:05 PM School Starts			PM. School Starts 11:35
	70 min. C 11:35 – 12:45	85 min. A 12:05 – 1:30	85 min. D 12:05 – 1:30	85 min. B 12:05 – 1:30	70 min. 3rd Block 11:35 – 12:45
	70 min. D 12:51 – 2:00	84 min. B 1:36 – 3:00	84 min. C 1:36 – 3:00	84 min. A 1:36 – 3:00	69 min. 4th Block 12:51 – 2.00
	45 min. PLC 2:15 – 3:00				

## JOHN BARSBY COMMUNITY SCHOOL

### Code of Conduct

John Barsby Community School strives to develop a safe, caring and inclusive and welcoming school environment that promotes the rights and responsibilities of all who learn and work here.

Our Code of Conduct reflects;

- the values of the *Nanaimo Ladysmith Public Schools 2.10 Inclusion Policy* that is based on the principles of respect, acceptance, safety and equity. It further affirms that “a learning environment that reflects diversity, inclusivity and equity is essential in supporting the highest level of individual growth and achievement.”
- the expectation that “that all students, staff, and members of our school communities will adhere to a code of conduct that is **educative, preventative** and **restorative** in practice and response”
- the purposes and intention of the *BC Human Rights Code(8.1b) 2017*

John Barsby School’s Code of Conduct expects that students will demonstrate socially responsible behaviors that reflect respect and safety at school and while attending a school function at any location at any time of day or day of week.

**Acceptable conduct:** refers to behavior that help to make the school a safe, caring and inclusive environment. The school community works with students to help them with learning responsible choices, safe behavior, problem solving, conflict resolution, respecting and restorative practices.

**Unacceptable conduct:** refers to behavior that interferes with the personal safety of others and the safe and orderly environment either of the school, person-to-person basis or through social media. Unacceptable conduct can take the form or bullying, harassment, intimidation, discrimination or illegal acts.

**Consequences:** to be equitable, consequences may vary from student to student where the misconduct appears to be similar. Intervention must be appropriate to the student’s age, maturity, needs, exceptionalities, extenuating circumstances and the nature of previous intervention, taking in consideration of the needs of the school.

**Restorative Practices:** focus on creating conditions for students to learn self-discipline, fix mistakes through addressing the needs of those who have been harmed and returning to the group/class/school strengthened. Students are encouraged, as often as possible, to participate in the development of meaningful interventions through discussion or mediation.

**Your beliefs become your thoughts & your thoughts become your words  
Your words become your actions & your actions become your destiny  
Mahatma Ghandi**

**An unabridged version of our school’s code of conduct is available on our website.**

## Behaviour Expectations for John Barsby Students

	<b>Awareness</b> <i>"I am aware of my own behaviour."</i>	<b>Character</b> <i>"I do what I say I'm going to do; I can be trusted."</i>	<b>Excellence</b> <i>"Through what I do impacts the world around me."</i>
<b>To Yourself</b>	Wear appropriate clothing Maintain personal hygiene Keep your body healthy Present yourself properly	Be honest Persevere through tasks Do what is expected and right Strive to accomplish personal goals	Attend all classes Arrive on time Bring materials Make up missed work
<b>To Others</b>	Hands/feet to yourself There is a time to listen and a time to speak Use appropriate language for the situation Use social media respectfully and responsibly	Be a good friend Be trustworthy	Admit, fix, and learn from your mistakes Be part of a productive learning environment Words are powerful...use them positively (no put downs) Accept others
<b>To Your Learning</b>	Appreciate others' right to learn Recognize your own learning opportunities	Try your best Do your own work Respectful use of cellphone	Complete all work Ask for help Listen to instruction Meet deadlines Study for tests & quizzes
<b>To the Environment</b>	Report vandalism/graffiti Clean up after yourself Use all equipment appropriately	Keep your school clean Make visitors feel welcome Participate/support school events/activities	Recycle Prevent vandalism
<b>To the Community</b>	Be aware of and respect the people around you Report any worrisome behaviours you witness at school or on social media	Pay it forward...do something nice for someone else Set a good example Be a positive role model	Make our community better for yourself and others

**Try your Best, Do the Right Thing,  
Get Better each Day - It's the Barsby Way!!**



## STUDENT ABSENCES AND LATES

Educational research has shown that regular, consistent attendance leads to academic success. We ask that parents/guardians phone in and excuse all absences (250-753-8211). Our office hours are from 8:00 a.m. to 3:30 p.m. Monday to Thursday and 8:00 a.m. to 2:30 p.m. on Fridays. We have an efficient and effective voice messaging system, so for your convenience, you may phone 24 hours a day, seven days a week. All legitimate absences must be parent/guardian excused. Students are required to provide a note to all their teachers upon their first day back. Please note that homework requests should be made for all multi-day absences to assist students in staying on top learning and decrease stress associated with missing class time.

## STUDENT EXPECTATIONS

### STUDENT DRIVER

Student drivers are reminded that they cannot drive other students to school events (before or after school). Student drivers are to drive responsibly in our school area – reasonable speed in the parking lot, exit area, and in front of the school.

### VISITOR/GUESTS

Students are required to obtain prior permission from an administrator to have a guest visit John Barsby Community School. Students are reminded that public schools are private property. Any student going to a school, other than their own requires prior permission from their own administration. Persons at a school site without permission may be deemed to be trespassing.

### Cell Phone/Electronic Devices

- During instructional time students are not to use any personal electronic device, unless deemed for educational purposes by the instructor of the class.
- Inappropriate use of technology within the building includes, but is not limited to loud music, recording of images, sound or video without explicit permission and sharing or transferring of others' personal information through social networking.
- John Barsby reserves the right to extend the school code of conduct policy on personal technology for the purpose of maintaining safety of students and staff.
- **John Barsby Community School is not responsible for electronic devices that are lost, stolen, or damaged while on school property.**

### PLAGIARISM AND CHEATING

Both of these are against our values as a learning community at John Barsby.

Students who cheat on tests or major assignments, plagiarize, or who allow another student to copy their work:

- a) May receive a zero mark
- b) Will have their parents contacted by the teacher
- c) May be referred to the office administration

### **DRESS CODE POLICY**

Students are allowed to wear anything they choose as long as it conforms with the school Code of Conduct requirements for the intended activity and does not promote drugs or alcohol, display offensive images or language, or encourage discrimination.

Appropriate dress is important in any school setting. Students' cleanliness, neatness, and appropriateness are all factors that transfer into their adult lives.

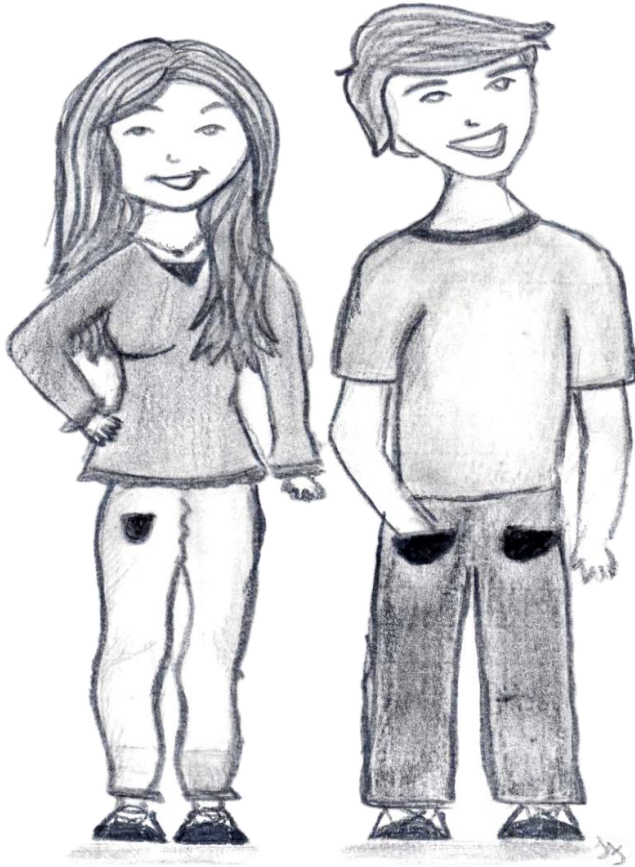

### **SMOKING, AND VAPING**

Students are reminded that there is no smoking, vaping, or chewing in the school building or on school property or in vehicles while you are on school grounds.

### **VANDALISM**

Any student who willfully or carelessly damages, destroys, or removes any school property without permission, will be held financially and/or restoratively responsible jointly with parents or guardians and could also face other discipline processes. Needless damage is not only displeasing but also very costly.

## **Fair Notice for Students**

### **What behaviours initiate a student threat assessment?**

A student threat assessment will be initiated when behaviours include but are not limited to: serious violence or violence with intent to harm or kill, verbal/written threats to harm/kill, Internet website/MSN threats to harm/kill, possession of weapons (including replicas), bomb threats and fire setting.

### **Duty to report**

In order to keep school communities safe and caring staff, parents/guardians/caregivers, students and community members must report all threat-related behaviours to the school principal.

### **What is a threat?**

A threat is an expression of intent to do harm or act out violently against someone or something. Threats may be verbal, written, drawn, posted on the Internet or made by gesture. Threats must be taken seriously, investigated and responded to.

### **What is a Site-Specific Threat Assessment Team?**

The school has a site-specific threat assessment team that includes the principal(s), counsellor(s), teachers and a member of the police.

### **The purposes of a student threat assessment are:**

- To ensure the safety of students, staff, parents and others
- To ensure a full understanding of the context of the threat
- To understand factors contributing to the threat makers' behaviour
- To be proactive in developing an intervention plan that addresses the emotional and physical safety of the threat maker
- To promote the emotional and physical safety of all

### **What happens in a student threat assessment?**

All threat making behaviour by a student shall be reported to the Principal who will activate the protocol for the initial response. Once the team has been activated, interviews may be held with the student(s), the threat maker, parents and staff to determine the level of risk and develop an appropriate response to the incident. Intervention plans will be developed and shared with parents, staff and students as required.

### **Can I refuse to participate in a threat assessment process?**

It is important for all parties to engage in the process. However, if for some reason there is a reluctance to participate in the process by the threat maker or parent / guardian, the threat assessment process will continue in order to promote a safe and caring learning environment.

### **Collection Notice**

The School District is subject to personal information privacy laws, and will undertake the collection of this information in compliance with the requirements of such laws; including by limiting collection to information that is relevant and necessary to address a risk or threat and by ensuring that information is collected from online open source sites. The School District will not collect information as part of a threat assessment unless there is reason to believe that a risk exists. Information collected as part of a threat assessment may be provided to law enforcement authorities in appropriate circumstances. (Safer

## **STUDENT SUPPORT TEAMS**

This year at Barsby, we have organized into teams to support our students. This is designed to increase communication, responsiveness and provide our families with a clear sense of who to connect with and what supports they can provide.

<b>Last names: A-L</b>		<b>Last names: M-Z</b>	
Vice-Principal	Jeff Hasenauer	Vice-Principal	Theresa Kraeker
Counsellor	Haley Healey	Counsellor	Natalie Sorensen
CYFSW	Cindi Ashbee	CYFSW	Margit Larsen-Rogers
Indigenous Support	Val White	Indigenous Support	Diane Neave
In-Reach	Mike Collier	In-Reach	Rob Stevenson

### **ADMINISTRATION**

The administration is available to answer any questions you may have about John Barsby Community School and the services we offer. We maintain an 'open door' policy and are enthusiastic to communicate with students, parents and the community in order to receive feedback about the services provided and changes we can make to improve.

Ms. Jane Reynolds, Principal  
Mr. Jeff Hasenauer, Vice-Principal  
Ms. Theresa Kraeker, Vice Principal

### **COUNSELLING**

All students at John Barsby have a counsellor assigned to them to assist them in a variety of ways. Counsellors are available for students and parents/guardians to help in any of the following areas: post-secondary planning, career development, educational planning, learning and study skills, inter-personal relations and communication, human development and social awareness. Counsellors work closely with students, parents, staff and community resources to make the high school years as valuable as possible for each individual in the school. Further to our own counselling services, the school has access to various district resources and community agencies to help students.

### **CHILD AND YOUTH CARE WORKER (SCHOOL BASED)**

The school's Child and Youth Care Workers will assist those students who are in need of extra support by connecting families with community support and/or community agencies. The Child and Youth Care Worker often works after hours and on weekends within the home with the child and the family.

**ABORIGINAL EDUCATION**

Aboriginal Education in School District 68 enriches the educational opportunities for all students. The goal of Aboriginal Education is to ensure that Aboriginal and non-Aboriginal students benefit from the services offered.

At John Barsby, enhancement opportunities are offered in the following ways:

<b>Academic Support by:</b> <ul style="list-style-type: none"><li>• Aboriginal Resource Teacher</li><li>• Aboriginal Education Assistant</li><li>• Aboriginal Tutor</li></ul>	<b>Cultural Appreciation through:</b> <ul style="list-style-type: none"><li>• Classroom Activities</li><li>• Community Activities</li><li>• School Activities</li><li>• Elder Presence</li></ul>
---	--

**In-Reach Support:** This year, we have added a new layer of support designed to be proactive, to help keep students connected to the school, caught up with their learning, and attending regularly. Our hope is that by flipping our former Out-Reach and Sr. Alternate programs to work with students before they stop attending that they will experience more success. John Barsby has a truly caring staff and fabulous supports that students can access if they just walk through the door.

Mike Collier (A-L) and Rob Stevenson (M-Z) each have some time in their schedules to work with students at the first indication that they are struggling. As we build this layer of support, it will be based on student needs. For the first term, In-Reach staff will mainly work with students on attendance issues; visiting home if necessary. They are also able to work with students who are falling behind in their courses and those who may be struggling with a variety of other issues by connecting them with resources.



## **STUDENT LIFE INFORMATION**

### **Social Media– How to be in the know – what is happening at JBCS!!**

**JBCS is on-line!** The site is updated regularly and displays special events and important calendar dates. The address of the website is: <http://jb.schools.sd68.bc.ca>. Please check the website daily. We also have Facebook and Instagram accounts.

### **FOOD SERVICES**

**Cafeteria:** The lunch time food service is operated by our Cafeteria Program. Chandler Hall is open during lunchtime each day and offers nutritious hot and cold items for reasonable prices! For weekly menu, please check the JBCS website. Students bringing a lunch are welcome to eat in Chandler hall.

**Breakfast/Lunch program:** Every day at 8:00 a.m. and lunchtime, before classes start, there is a variety of healthy food available for students in Room 300, free of charge. We ask that students support the food program by keeping the room clean, putting away dishes, and being respectful of others within the room.

### **FIRST AID SERVICES**

Students who are ill or injured must report to a secretary in the main office. A first aid room is available for short term use only. If necessary, a first aid attendant will be called to examine the student. JBCS staff can provide emergency first aid, however, if a student is too ill to continue classes, he/she will be sent home for the day.

### **JOHN BARSBY WELLNESS CENTRE**

The John Barsby Wellness Centre is now open for its fifth year. The Wellness Centre is located in the school next to the Counselling Office. It is staffed Monday, Wednesday and Friday with a Public Health nurse. Hours are posted on the door with any variations to the school day hours. Doctors also provide care, just like a doctor's office. The hours are posted, and students can drop-in to see the doctor for any health related questions or concerns. Services that are available from the nurse include immunizations, referrals to mental health and counselling, birth control, emergency contraception, and STI testing. The center is ever expanding and currently we have a great staff and we work closely with services such as Discovery Youth and Substance Services, Child Youth Mental Health, Haven and many others. For now, the Wellness Centre is accessible to the students of John Barsby but if any parents have questions and would like to talk to the nurse or staff, please call the Wellness Centre at 250-753-8211 local 288. All services are confidential.

### **STUDENT CARDS**

Student cards can be purchased for \$15. We encourage all students to get involved in both curricular and extra-curricular activities. The card also provides students with an opportunity to participate in various events that will occur during the school year, throughout the city.

### **YEARBOOK**

Take pride in celebrating your year, your school, your place in time, and your story. We promise to deliver a yearbook that brings people together. The rest of the world will change, but the yearbook preserves the events and emotions of the year forever. The cost is \$45.00.

### **CLUBS AND ACTIVITIES**

School clubs and activities are another area in which students can get involved in their school and meet new friends. They allow both staff and students to pursue common interests in a non-curricular and informal setting. Although available choices may vary from year to year, a wide variety of sponsored clubs and activities are offered at John Barsby.

### **GYM RULES**

John Barsby welcomes all JBCS students, visiting teams, officials and spectators to our school!

To make every event enjoyable for all those involved, we would ask that the beliefs that we hold at our school be respected by all those using the gym area:

- No food or drink at any time (except capped water)
- Encourage and acknowledge good play by both teams
- Respect the officials and their decisions
- Respect the players, coaches and their support staff
- Respect the gym and the other facilities. Violators may be banned from the Gym. Please do not leave a mess in the stands or at the team benches.
- “We participate in athletics for the love of the sport, but we also put it in perspective; at the end of the day, it is just a game.”
- Cheer for your team – not against your opponent

Items that are “stolen” from lockers, change rooms and classrooms are the responsibility of the student. If a student has lost items, please take the following steps:

- Inform the classroom teacher
- Inform the office and an Administrator

The school does not have the resources to replace stolen items but will take steps in helping with the investigation. This could include contact with the school RCMP Liaison Officer.



### **STUDENT PHOTOS:**

This year the photographer will be in the school on **September 19th** to take individual photographs. Students wishing to purchase a package of photographs will be required to make payment to the photographer on that day. Retakes are scheduled for **October 24<sup>th</sup>**. These photographs will be used for student cards and yearbook; therefore, *all* students are asked to have their pictures taken without cost.

### **TEXTBOOKS:**

Teachers issue textbooks as required and keep an electronic record of the texts issued. Charges will be assessed for books lost, stolen or damaged. Please take care of the books. ONCE ASSIGNED TO YOU, THEY ARE YOUR RESPONSIBILITY.

### **RECYCLING:**

It *is* easy being green! Waste management is a huge part of making our ecological footprint on the earth smaller. Recycling is easy and its impacts are incredible. Let's make Barsby a GREEN campus!

At John Barsby, we have four streams of solid waste which exit the school: organics, plastic and glass recycling, paper recycling, and landfill. By diverting a good portion of our waste into the other streams, we divert waste from the landfill, helping to minimize the amount of garbage we produce and thus making our school a more sustainable one.

### **STUDY HALL:**

After school in Room 234 on Tuesday and Thursday. Help with your homework, assignments, projects, and test preparation in any subject. See counsellors or email Ms. Rynanen at [bryynanen@sd68.bc.ca](mailto:bryynanen@sd68.bc.ca).

### **KEEPING YOUR BELONGINGS SAFE**

#### **Bicycles:**

A bicycle rack is provided outside the front of the school by the front entrance. Students are encouraged to lock bicycles to the rack. There is no inside storage available for bicycles. The school assumes no responsibility for theft or damage of bicycles. **DO NOT LEAVE BICYCLES UNLOCKED OR ON SCHOOL GROUNDS OVERNIGHT!**

**Gym lockers:** Available for class use only – Please label all gym clothing and equipment. Labeling of clothing and belongings with the owner's name will reduce losses. Report any loss immediately to your teacher. **Please do not leave anything of value (e.g. electronics)** in the gym or locker room. **LOCK IT UP!!**

## REPORTING

### GRADE 8 AND 9 REPORTING

In Nanaimo Ladysmith Public Schools, we are moving to ‘communicating student learning with parents’ on an ongoing basis. We recognize that we are on a learning journey as we move through this process. We will work towards providing parents with timely and responsive communication of student learning throughout the year, following district policies and procedures.

Communication will occur a minimum of five times during a school year:

- A. Ongoing Communications of Student Learning
  - Minimum of three times throughout the school year
  - One of the three can be the parent teacher conference
  
- B. Two Written Summative Reports
  - end of January / end of June, includes student self-reporting of core competencies
  - reporting no longer requires letter grades

### GRADE 10 – 11 – 12 REPORTING

Four report cards a year are sent home to parents: at mid-November, early February (end of first semester), mid-April and late June. Barsby also has parent/teacher nights. Conferences are held so that parents and students may discuss the progress of their child with subject teachers. Please note that parents are welcome to arrange to communicate with teachers at other times and by other means (ex: telephone or email). Please refer to the calendar or website. For each course, the report cards summarize achievement, work habits and attendance. The traditional letter grades and percentages are used to report on student academic achievement.

In addition, teachers send an “Interim Report” to parents at a time other than those indicated above; the Interim Report is designed to report success to parents, or to alert them to a problem in a given course.

## HOMEWORK AND STUDY

**Personal Planners are recommended for every student – planners are provided for Grade 8 students.**

Homework is an important part of the school program. It is very important that homework assignments are recorded in the student’s planner and completed by the due date as work which follows in class is often based upon such assignments.

Parents can assist by:

- Providing a quiet, well-lit place for study.
- Ensuring that time is set aside each day for study.
- Reminding the student of his/her home study responsibility.
- Contacting the school if there are concerns about the amount or type of homework.
- Checking student’s planner

## SAFETY

### SECURITY CAMERAS

All students have the right to learn in a safe environment. Areas of John Barsby Community School and its property are under 24-hour surveillance. Footage of inappropriate or illegal activities will be used, and provided, upon request, to the police/authorities.

### SCHOOL CLOSURE INFORMATION

School may be cancelled or delayed in case of snow, extreme cold or other emergency situations. When the weather is bad, but school is open, parents/guardians must make a family decision regarding attendance or late arrival for their children. A personal contact by the parent/guardian or a written note will excuse a student's late arrival or absence during these conditions.

*Is my child's school closed? Tune into one of the following radio stations:*

**CKWV 102.3 FM (WAVE) – 250-758-1131**

**CHWF 106.9 FM (WOLF) – 250-758-2467**

You can also check for school closures on the School District's website: [www.sd68.bc.ca](http://www.sd68.bc.ca) or on twitter at sd68bc.

### Medical Alerts

Teachers will be provided with a confidential list of students with life threatening illnesses/conditions, as well as appropriate treatments. Please ensure that you provide the office with updated and correct information in this regard.

### FIRE EVACUATION PROCEDURE

Teachers will advise classes of the appropriate exit from each room at the beginning of the year. Drills will be conducted throughout the school year. If the fire alarm bell rings:

- Teacher will direct the students to exit and will lead the class out of the building via the appropriate exit to the assembly area on the soccer field in front of the school.
- Students are to act in a quiet and orderly manner following the directions of the teachers and staff.

## **EARTHQUAKE EVACUATION PROCEDURE**

Earthquake drills will be conducted during the year. Students will be given specific instructions from classroom teachers in regard to earthquake drill procedures.

In the event of an earthquake students should:

- Drop, cover, hold, and count aloud until quake ends.
- Wait quietly and listen for instructions from your teacher.
- Your teacher will instruct you to check carefully for injuries and dangerous objects before moving and standing up.
- If your teacher is injured, two designated students will give instructions to the class.
- When instructed, students will evacuate the building in single file with shoes on.
- Walk slowly, shuffling feet to ensure no debris is underfoot, and look up, down, left and right for dangers.
- Students will be lead to an assembly area by their teachers.
- Students must wait to be reunited with parents/guardians.

## **EMERGENCY ANNOUNCEMENTS**

At times it may be necessary to communicate with staff and students regarding a safety issue via the PA system. More detailed information is provided in the student safety brochure. The following announcements have been established:

### Initiate Lockdown

- Students are to remain in their classroom. Students in the hallway should go directly to the nearest classroom.
- Students are to duck and cover, staying away from windows, outside walls and doors.
- Cell phones are to be turned off.
- Follow the directions of the teachers and staff.

### Hold and Secure

- Students are to remain in their classroom. Students in the hallway should go directly to the nearest classroom.
- Follow the directions of the teachers and staff.

### All Clear

- Resume normal activities.

## **ELEVATOR**

Students who are medically unable to climb stairs may use the elevator by signing out a key from the office.